



TECHNICAL DATA SHEET

Q-Sync[®] HVAC Permanent Magnet Synchronous Fan Motors

Ground-breaking technology that increases your system's SEER rating.

- Minimize the system's compressor and condenser sizes AND achieve required SEER levels
- Better control of airflow with precise speed control and no speed droop
- More efficient motors with power factors near unity



Q-Sync[®] HVAC 1/2Hp 60Hz

PRODUCT SPECIFICATIONS

Q-Sync[®] HVAC Synchronous Motor

Model QSM0.50-3C-CC		
	120 VAC	230 VAC
Customer model	30090	30090
Voltage Range	95-132 V	176-264 V
Running Current (Amps)	3.67 A	1.84 A
Locked Rotor Current (Amps)	10 A	5 A
Horse Power	1/2 Hp	1/2 Hp
Watts	375 W	375 W
Variable Speed	600-1200 RPM	600-1200 RPM
Frequency	60 Hz	60 Hz
Rotation (opposite end of shaft)	CC-CW	CC-CW
Phase	1	1
Temp	-40°C to +55°C	-40°C to +55°C
Protection	Impedance Protected	Impedance Protected
CSA / UL File Number	E465664	E465664
Class	Class A (105 C)	Class A (105 C)
Motor Type	Continuous Air Over	Continuous Air Over
Plug	Not Supplied	Not Supplied
Standard 1/2" electrical access hole	1/2 Inch Access Hole	1/2 Inch Access Hole
3/16 Faston connections to Circuit Board	3/16 in	3/16 in
Motor Length	7.51 in	7.51 in
Shaft diameter	0.5 in	0.5 in
Shaft Mounting	0.455 Flat	0.455 Flat
Shaft Length	4.96 in	4.96 in
4 hole, 1/4-20 UNC on 3.75 diameter	4 Hole Front Mount	4 Hole Front Mount
Moisture Protection	IP65	IP65
Weight Motor Only	22.0 lbs	22.0 lbs
Efficiency @375W (rated power)	91.13%	91.00%
Power Factor	0.94	0.94

IP65
CERTIFIED

UL[®]
cRU^s

CE

UL 1004-2
UL 60730-1

ASSEMBLY

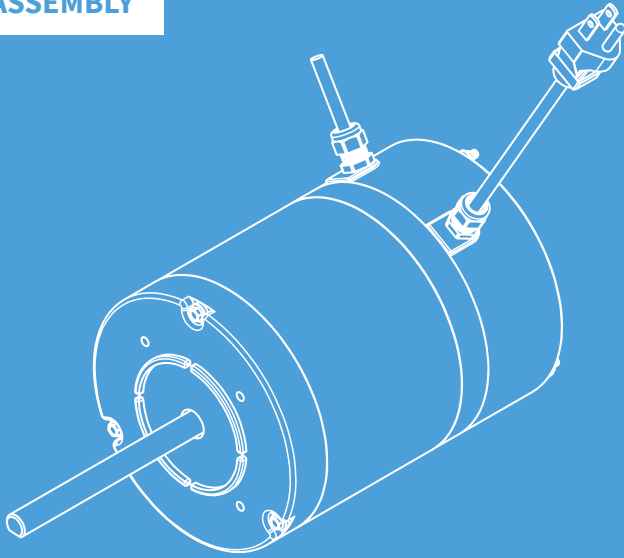

PARTS LIST

Item	Qty	Part #	Description
1	1	30091	Wound Stator Assembly, 1/2 Hp
2	1	30092	Rotor Assembly
3	1	40056	Front Cover
4	1	40081	Mid Cover
5	1	40188	Rear Cover
6	1	40085	Case
7	1	30093	Power Cord Assembly
8	1	30220	Sensor Cable Assembly (1/2 Hp)
9	1	30202	PCB Assembly, Motor Control
10	1	60135	Wave Disc Spring
11	1	40060	Thermal Pad (A)
12	3	60086	Screw, Pan HD 4-40 x .375 LG (91772A108)
13	6	60149	Neoprene Rubber Sealing Washer, 18-8 SS, No. 8 (94709A112)
14	3	60141	Screw, Soc HD, SS, 6-32 x .250 LG (92196A144)
15	3	60084	Screw, Hex HD, 8-32 x 7.75 LG
16	6	60142	Hex Nut, 8-32, Narrow
17	3	60143	Split Lock Washer, No. 8 (98437A106)
18	3	60150	O-Ring, EPDM Rubber, .070 DIA (9557K141)
19	1	30238	Sensing Cord Assembly

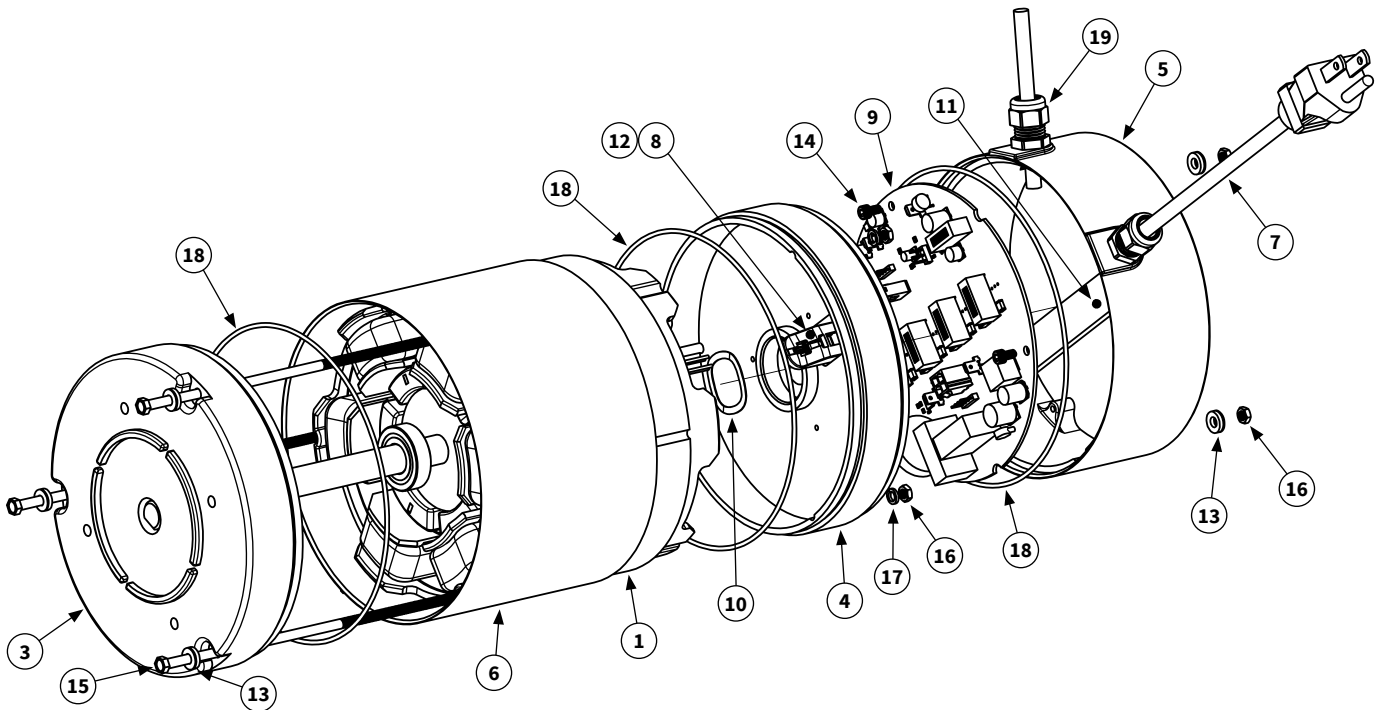

NOTICE OF CONFIDENTIAL INFORMATION

Information contained herein is Confidential. Where furnished with a proposal, the recipient shall use it solely for the purposes of inspection, installation, or maintenance. Where furnished to a supplier, it shall be used solely in the performance of the contract. The information shall not be used or disclosed by the recipient for any other purpose.

QM Power, Inc.
 9680 Marion Ridge
 Kansas City, MO 64137
 P (816) 246-4200 | sales@qmpower.com
www.qmpower.com